

MADE IN ITALY

B

INTERNI

cucine

E

FEB. 2019

Rinascimento
Renaissance

A SELECTION OF BATHROOMS AND CLOSETS
DESIGNED AND PRODUCED IN ITALY

UNA SELECCIÓN DE BAÑOS Y CLOSETS
DISEÑADOS Y PRODUCIDOS EN ITALIA

Rinascimento

Renaissance

This is our renaissance. A new way of looking at **space and compositional geometries**, featuring a few select models and the trendiest finishes to furnish your home with clean lines and sophisticated materials.

We draw on our knowledge of bathroom and closet environments acquired in Italy, to bring to America the culture that distinguishes Italians around the world as inspired crafters.

Welcome back to the basics.

*Se trata de nuestro renacimiento. Una nueva forma de mirar **las geometrías de composición y espacio**, con algunos modelos selectos y acabados vanguardistas, para moblar su hogar con líneas limpias y materiales sofisticados.*

Nos basamos en nuestro conocimiento de ambientes de baño y armario adquirido en Italia, para llevar a América la cultura que distingue a los italianos alrededor del mundo como artesanos inspirados.

¡Bienvenido de nuevo a lo básico.

A brand with a meaning,
a brand that is a statement.

*Una marca con un
significado, una marca
que es una declaración.*



02 Company manifesto

Bathroom models

- 07 Raffaello - #01
- 12 Raffaello - #02
- 16 Raffaello - #03
- 20 Raffaello - #04
- 26 Raffaello - #05

Wardrobe models

- 32 Dante - #01
- 36 Dante - #02

INTERNI is an Italian word, a word which means INTERIORS.

With this name, we want to communicate that **we are an interior manufacturing company**, with our Italian identity clearly expressed.

We don't use Italian names or Italian sounds just to confuse our clients.

We use an Italian name and the Italian Flag because **we are Italians and our products are 100% Made in Italy.**

INTERNI es una palabra italiana que significa **INTERIORES.**

Con este nombre, queremos comunicar que somos una **empresa de fabricación de interiores**, con nuestra identidad italiana expresado claramente.

No utilizamos nombres italianos o sonidos italianos sólo para confundir a nuestros clientes.

Usamos un nombre italiano y la bandera italiana porque **somos italianos y nuestros productos son 100% Hecho en Italia.**

AVAILABLE DOORS AND STRUCTURE FINISHES

ACABADOS Y PUERTAS DISPONIBLES

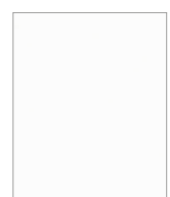
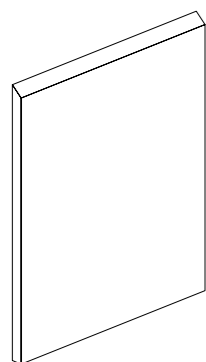

Fenix Bianco



Fenix Grigio Londra



Rovere Nodato



Pietra

45° DOOR

Door with hollow grip profile for base and column cabinets, featuring a 45 degree edge which does not require an additional handle.

PUERTA 45°

Puerta con perfil integrado para unidades de base y columna, cuenta con un borde de 45 grados que no requiere manija adicional.

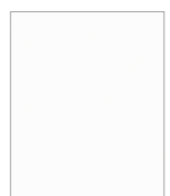
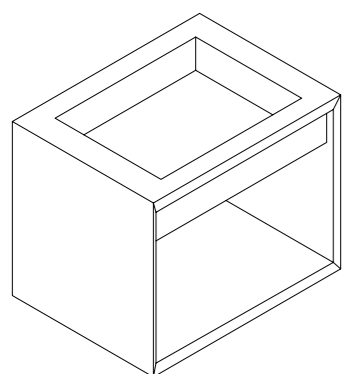

Fenix Bianco



Fenix Grigio Londra

BOXES

All boxes come with a Fenix finish, a new generation smart material for interior design. With low light reflectivity, the surface is extremely opaque, anti-fingerprint and pleasantly soft to the touch. Superficial microscratches can be repaired thermally.

AVAILABLE DOORS AND STRUCTURE FINISHES

ACABADOS Y PUERTAS DISPONIBLES

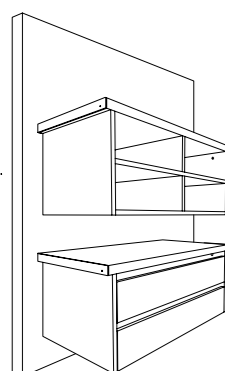

Rovere Moro

CLOSETS

Interior Cucine's closets are minimal walk-in closets, with gray metal elements and Rovere Moro wooden surfaces, which fit and organize any space.

The Renaissance is a period in European history, marking the transition from the Middle Ages to modernity.

MANY OF THE FAMOUS ARTISTS WHO PAINTED ALTARPIECES AND FRESCOES IN ITALY WERE ALSO INVOLVED IN THE DECORATION OF CHOIR-BOOKS FOR THE MOST IMPORTANT CHURCHES AND MONASTERIES.

El renacimiento es un período en la historia europea, marcando la transición de la edad media a la modernidad.

MUCHOS DE LOS FAMOSOS ARTISTAS QUE PINTARON RETABLOS Y FRESCOS EN ITALIA TAMBIÉN PARTICIPARON EN LA DECORACIÓN DE LIBROS DE CORO DE LO S MÁS IMPORTANTES IGLESIAS Y MONASTERIOS.

Renaissance means “rebirth” in Italian.

The Renaissance, as a cultural movement, involved art, architecture, politics, science and literature.

Renacimiento significa “renacer” en Italiano.

El renacimiento, como movimiento cultural, involucro arte, arquitectura, política, ciencia y literatura.

The artistic and decorative culture of the past finds new inspiration in the exaltation of simple materials and shapes.

Nowadays, talking about renaissance may seem like a step backwards, but its message and the meaning of the word itself, “rebirth”, inspired this collection:

A reinterpretation of materials and geometries that starts from new technological possibilities and new styles.

If in ancient times the value of an object derived from craftsmanship and decorum applied to a piece of furniture, today are the immediacy of the material and geometric minimalism to strike our imagination, attracting our attention with important volumes of precious materials, magically suspended in air or on ephemeral structures. A taste that has been refined throughout Europe, shaped by time and changes in style and technology, is now available as a quality choice for a competitive price even in America.

Hoy en día, hablar de renacimiento puede parecer un paso atrás, pero su mensaje y el significado de la palabra “renacimiento”, han inspirado esta colección.

Una reinterpretación de materiales y geometrías que empieza de nuevas posibilidades tecnológicas y nuevos estilos.

Si en la antigüedad el valor de un objeto derivaba de la artesanía y decoro aplicado a un pedazo de muebles, hoy en día son la inmediatez de materiales y el minimalismo geométrico huelga nuestra imaginación, trayendo nuestra atención con volúmenes importantes de preciosos materiales, mágicamente suspendidos en el aire o en estructuras efímeras. Un gusto que ha sido perfeccionado a lo largo de Europa, formado por el tiempo y cambios en estilo y tecnología, está ahora disponible como una opción de calidad a un precio competitivo incluso en los Estados Unidos.

Italian quality,
made to last.

We believe in a bathroom and a wardrobe whose **clean shapes and materials** embellish the room with their own presence,

in complete harmony with the surfaces of contemporary environments; proud of the quality of our structures, **solid** like woods or marbles of our finishes.

*Calidad italiana,
hecho para durar.*

*Creemos en un cuarto de baño y un armario cuyas **formas limpias y materiales** embellecen la sala con su propia presencia,*

*en completa armonía con las superficies de los ambientes contemporáneos; orgullosos de la calidad de nuestras estructuras, **sólidos como maderas o mármoles** de nuestros acabados.*

THE ABC OF A
GOOD PROJECT

M

RAW MATERIALS FROM
RENEWABLE SOURCES
*MATERIAS PRIMAS DE
FUENTES RENOVABLES*

D

PRECISE DESIGN
DISEÑO PRECISO

Q

QUALITY CONTROL
CONTROL DE CALIDAD

S

AFTER SALE
SERVICES
*SERVICIO DESPUES
DE LA VENTA*

**100%
MADE
IN ITALY**

Every step in the production of every **INTERNI** cucine bathroom and closet follows strict European regulations, **design standards and quality control checks**. And, because our bathrooms and closets are produced in Italy for enjoyment in America, our approach to solid construction, **modular design and fast delivery** ensures an **easy installation** and your ultimate satisfaction with our product.

*Cada paso en la producción de cada baño **INTERNI** cucine sigue estrictas normas europeas, **normas de diseño y controles de calidad**. Y, porque nuestros cuartos de baño y armarios son producidos en Italia para disfrute en América, nuestro enfoque en la construcción sólida, **diseño modular y entrega rápida** aseguran una **fácil instalación** y su máxima satisfacción con nuestro producto.*

A century of
expertise.

Our business concept is based on a **select group of quality Italian manufacturers**, partnered together to offer their products directly to the American market, for both retail and contractor projects, without a middleman to increase costs to the consumer.

*Más de un siglo
de experiencia.*

*Nuestro concepto de negocio se basa en un **selecto grupo de fabricantes italianos** de calidad, asociados para ofrecer sus productos directamente al mercado estadounidense, para proyectos al por menor y también al por mayor, sin intermediarios que incrementan los costos al consumidor.*

These combined stories
bring together
more than 110 years
of expertise.

Estas historias combinadas reúnen a más de 110 años de experiencia.

In our factories in Italy, we use **eco-friendly and noble materials** in our construction, together with real Italian craftsmanship and attention to detail.

In the United States, we have a **network of thousands of distribution points** and shops equipped with Italian woodworking machinery and painting plants to adequately support all of our retailer, designer and consumer needs.

*En nuestras fábricas en Italia, utilizamos **materiales nobles y ecológicos** en nuestra construcción, junto con la **artesanía italiana** y atención al detalle.*

*En los Estados Unidos, contamos con una **red de miles de puntos de distribución** y tiendas equipadas con maquinaria italiana para la madera y plantas de pintura para **apoyar adecuadamente a todas las necesidades del diseñador y el consumidor**.*

ROOTED IN TRADITION,
GROWN WITH CULTURE
AND TECHNOLOGY

ARRAIGADO EN LA
TRADICIÓN, CRIADO CON
CULTURA Y TECNOLOGÍA



D^{.01}

Corner open closet in Rovere Moro with storage shelves, hanging rods, wall units and shoe shelves.

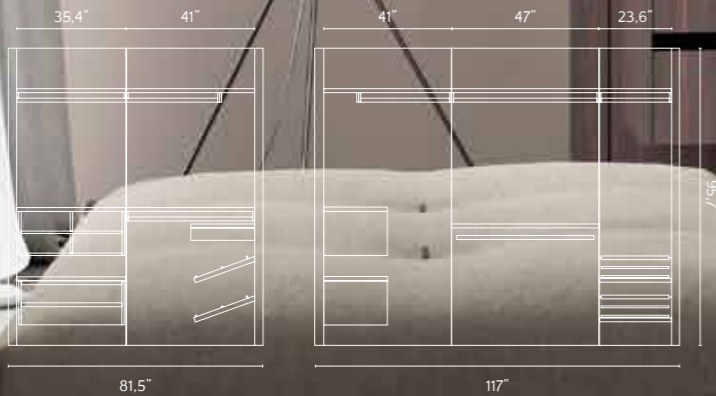



Dante

.01



Brunelleschi formulated the Renaissance architectural style emulating and improving classical forms, simplifying them with platonic solids.

Brunelleschi formulo el estilo arquitectónico del renacimiento emulando y mejorando las formas clásicas, simplificando las con sólidos platónicos.

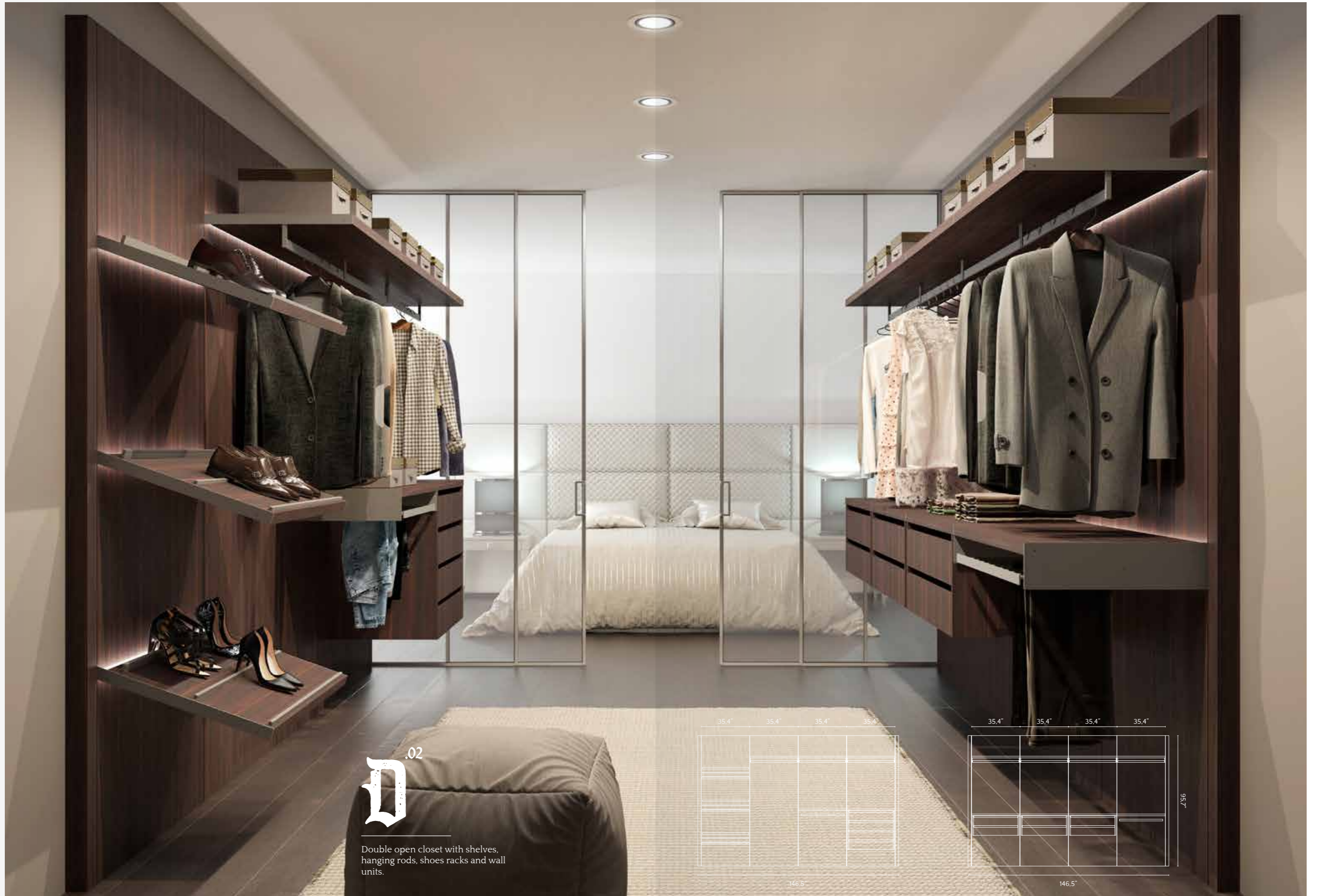

.02
D

Double open closet with shelves, hanging rods, shoes racks and wall units.

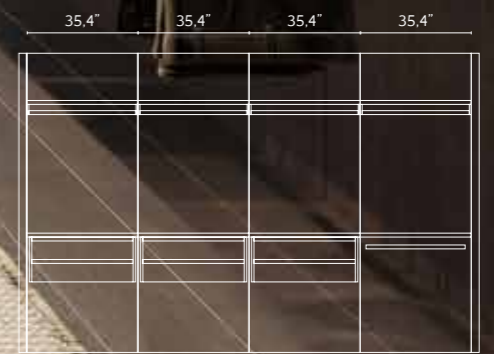
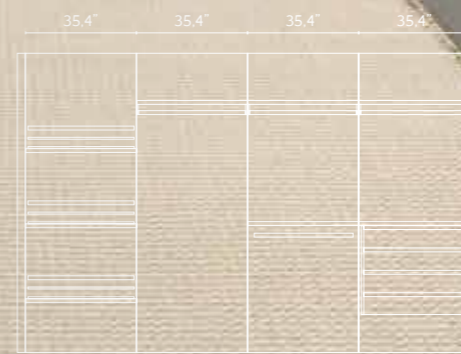

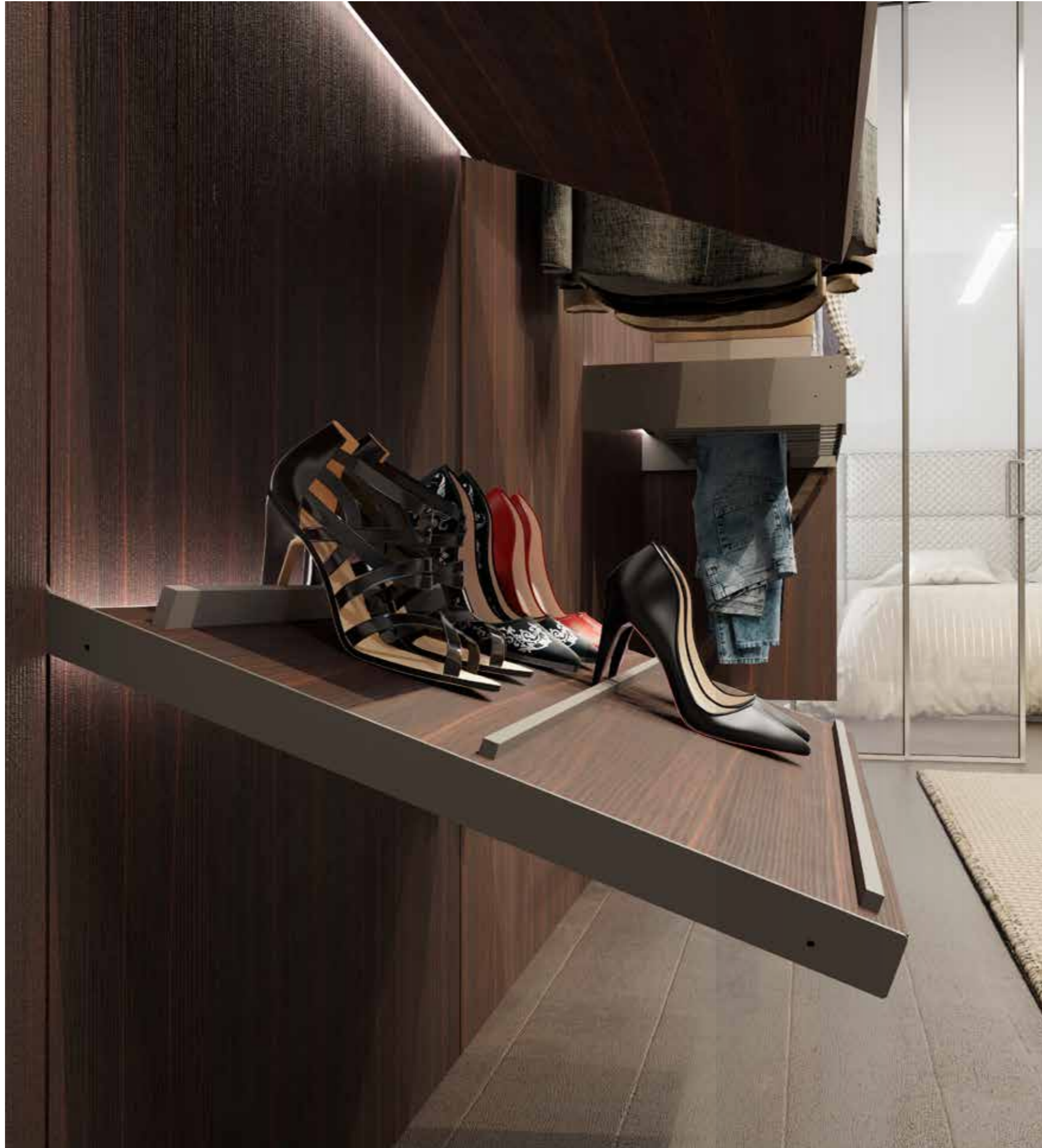

Dante - #02

Detail of shoes shelf.



Dante

During the Renaissance, architects used additional columns and arcades as decorative elements. Now the minimalistic design trend aims to highlight the structure of things in a rational layout.

Durante el renacimiento, los arquitectos utilizaron columnas adicionales y arcadas como elementos decorativos. Ahora la tendencia de diseño minimalista pretende destacar la estructura de las cosas en una disposición racional.



WARRANTY NOTES

Your happiness with your new **INTERNI cucine** cabinets is important to us.

What does the warranty cover?

Products supplied by **INTERNI cucine** to be free of defects in materials and workmanship under normal home use and service.

What will INTERNI cucine do?

INTERNI cucine will examine the product and decide, at its sole discretion, if it is covered under this warranty. If considered covered, **INTERNI cucine** will either replace defective product or repair any defects. In keeping with our policy of continued product improvement, **INTERNI cucine** reserves the right to change product specifications without notice. If a warranty claim is filed after a product has become obsolete, or has undergone design changes, we will honor the warranty in one of the following manners:

- To replace the affected component with a new component of the same style.
- To replace the affected component that is as similar and comparable in style as possible.

If components are replaced, we cannot guarantee that the finish of the new component will match the finish and appearance of existing cabinetry.

This warranty gives you specific legal rights and you may have other rights, which vary from state to state and province to province. Some states or provinces do not allow the exclusion or limitation of incidental or consequential damages, so the above limitations or exclusions may not apply to you.

We stand behind all of our cabinets and offer you our Limited Lifetime Warranty that covers defects in the material and workmanship on **INTERNI cucine** products. This warranty is valid for domestic kitchen use and is subject to the terms and conditions stated below. Valid for indoor use only.

How long does the warranty last?

This warranty lasts for as long as the initial purchaser of the products owns them at the original site of installation beginning upon date of delivery to you. In a residential application and non-transferable to the subsequent owner.

What does the warranty not cover?

This warranty does not cover or extend to:

- The natural aging or darkening of wood color, the inherent growth characteristics of, or variations in wood. This is the beauty of the wood and not a defect.
- Products or parts purchased from a non authorized **INTERNI cucine** dealer.
- Defects caused by improper handling, storage, installation, assembly or disassembly, intentional damage, product modifications, exposure to the elements including humidity which may result in warping or splitting, accidental misuse, abuse or negligence.
- Normal wear and tear, cuts or scratches, or damage caused by impacts or accidents
- Removal, shipping or reinstallation on any items or products.

INTERNI CUCINE
IS PROUD MEMBER OF:



CREDITS:

Spezie - Spices (February 2019)
Design & Concept: Neiko
Images: Neiko
Printed in Italy by: Grafiche Antiga

1783 NW 38th Ave - Fort Lauderdale, FL 33311
Phone: +1 (954) 486-7000

NOTICE: *NOTICIA:*

INTERNI cucine reserves the right to modify the technical characteristics of the elements contained in this catalogue without notice and shall not be liable for any inexactness contained herein.

INTERNI cucine se reserva el derecho de modificar las características técnicas de los elementos contenidos en este catálogo sin previo aviso y no será responsable por cualesquiera inexactitudes contenidas en el presente.



A reinterpretation of materials and geometries that starts from new technological possibilities and new styles.

Bathroom and closet furniture with **clean shapes and materials** that embellish the room with their own presence, in complete harmony with the surfaces of contemporary environments.

Una reinterpretación de materiales y geometrías que empieza de nuevas posibilidades tecnológicas y nuevos estilos.

Muebles de baño y armarios con formas limpias y materiales que embellecen la sala con su propia presencia, en completa armonía con las superficies de los ambientes contemporáneos.

INTERNI

cucine

1783 NW 38th Ave
Fort Lauderdale, FL 33311
Phone: +1 (954) 486-7000